



996/997 Eccentric Adjuster Locking Kit- Installation Instructions Patent Pending

Part Numbers: 2180017, 2180019

Cars applicable:

2180017 - 993, 996, 997, 986, 987, 991, 981 : Toe and Camber

2180019 - 993 : Toe, Camber, and Kinematic Toe

Parts list:

Description	Quantity Included by Part Number	
	2180017	2180019
Locking Washer	4	6



Tools Required:

- Basic Mechanic's Tool set

Introduction:

Congratulations on your selection of the Elephant Racing Eccentric Adjuster Locking kit!

Under high lateral load, factory eccentric adjusters are known to slip. When this happens, your rear toe or camber settings can quickly swing out of adjustment, something you definitely don't want to happen mid-corner!

The kit includes Locking Washers that work in combination with your factory eccentric adjusters and prevents them from slipping. The Locking Washers function by increasing the friction that holds the factory eccentric adjusters in place.

The adjusting feature of the factory eccentrics remains functional, thus allowing use of the original fixed length factory lower control arms and toe links.

Step-by-Step Installation:

996 / 997 / 986 / 987

1 – Safely raise and secure the vehicle at approved lifting points per an appropriate shop manual.

2 – Note the positioning of the eccentric bolt on the rear toe rod and lower control arm. Where applicable, mark these positions for ease of future installation.

3 – Loosen and remove the applicable rear eccentric bolts.



4 – Install the Locking Washers.

Important: Locking Washers must be installed such that the slot crosses the subframe slot as shown. Failure to do this will render the Locking Washers ineffective.



Toe Adjuster / Track Rod:

996: Place one Locking Washer on the side of the sub-frame mounting point closest to the rear of the car.

997: Place one Locking Washer on the side of the sub-frame mounting point closest to the front of the car.

Lower Control Arm: Place one Locking Washer on the side closest to the front of the car.

Locking Washer Installation Locations.

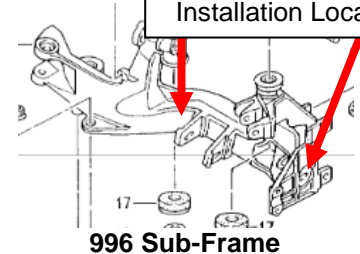

996 Sub-Frame

Locking Washer Installation Locations.

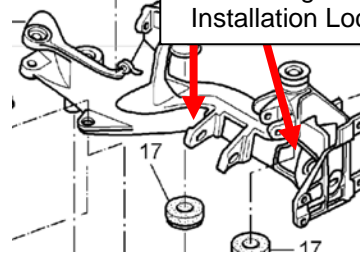

997 Sub-Frame

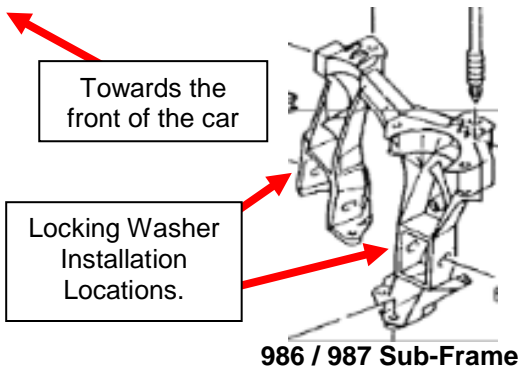

Towards the front of the car

Locking Washer Installation Locations.

986 / 987 Sub-Frame

5 – Reinstall the eccentric adjusting bolts, indexing to the locations marked in step 2. Tighten per the specified torque value as found in an appropriate shop manual.



6 – Test drive the vehicle to ensure proper suspension operation. Elephant Racing recommends having the car aligned by a trained professional following installation of this product.

993

1 – Safely raise and secure the vehicle at approved lifting points per an appropriate shop manual.

2 – Note the positioning of the eccentric bolts on the upper control arms and toe rod. Where applicable, mark these positions for ease of future installation.

3 – Loosen and remove the applicable rear eccentric bolts.

4 – Install the Locking Washers per the figure to the right.

Forward Upper Control Arm: Place one Locking Washer on one side of the sub-frame mounting point.

Rearward Upper Control Arm (Camber): Place one Locking Washer on the side of the sub-frame mounting point closest to the rear of the car.

Kinematic Toe Rod: Place one Locking Washer on one side of the cross member mounting point

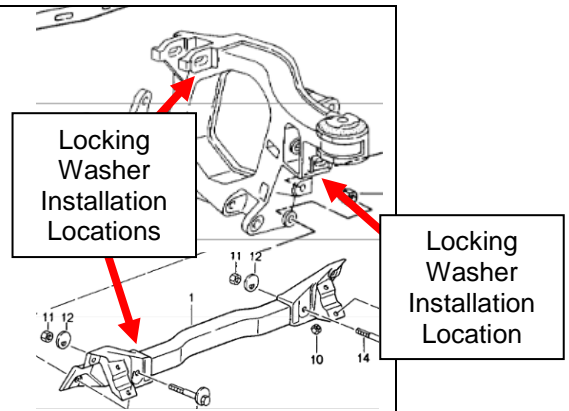

5 – Reinstall the eccentric adjusting bolts, indexing to the locations marked in step 2. Tighten per the specified torque value as found in an appropriate shop manual.

6 – Test drive the vehicle to ensure proper suspension operation. Elephant Racing recommends having the car aligned by a trained professional following installation of this product.



This page intentionally left blank